

Installation and operating Instruction Combined Gas Valve M*N

*Combined gas valve
with 2 safety valves
for light commercial
pressure jet burners.*

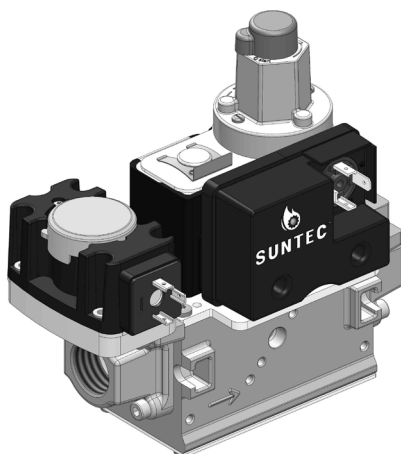

Application

The use of the SUNTEC M*N combined gas valve is recommended for all gaseous fuel appliances where safety shutoff is required. It is suitable for use with 1st, 2nd and 3rd family gases, according to EN 437, for inlet pressure up to 360mbar (for M2 range) and to 160mbar (for M3 range).

M2 and M3 combined gas valve are available with 2 options : fast opening (M*N**F) or slow opening (M*N**S).

Approvals

SUNTEC M*N combined gas valve meets all the specifications of EN 13611 and EN 161 standards. It complies with requirements of gas regulation (EU) 2016/426 on appliances burning gaseous fuels (CE certificate : 1312CU6361).

Technical specifications

General

Functioning with	Air and gas of 1st, 2nd and 3rd families, according to EN 437
Maximum operating pressure	<ul style="list-style-type: none">M2N : 360 mbarM3N : 160 mbar
Pipe sizes	Inlet / outlet connection with straight flange : DN15 (Rp1/2'') or DN20 (Rp3/4''). Internal thread according to EN 10226-1.
Torsion / Bending stress	M*N gas valve fulfill group 2 requirements, according to EN 13611
Housing	Aluminium
Ambiant temperature range	-20°C to +60°C
Weight	<ul style="list-style-type: none">M*N**F : 2.3kgM*N**S : 2.5kg
Expected lifetime	Safety shut-off valves have been certified for 200 000 ON/OFF operations according to EN 161 standard.
Pressure taps	G1/8 connections supplied in 3 locations on the combined gas valve (see section "Pressure tap / pressure plugs identification", page 8), and on inlet/outlet flanges.
Seals and gaskets	All NBR compounds, B2H2 and B2H3 according to EN549.
Inlet strainer	Fine square mesh : \square 0.6 mm, AISI 304 steel \varnothing 0.14mm wire
Minimum pressure switch (optional)	Factory mounted on inlet flange. When suitable configuration (see page 8), can be side-mounted («P3» tap).

Safety valves

Safety Valves (V1 and V2)	<ul style="list-style-type: none">M2N : Class A+A, according to EN 161M3N : Class B+B, according to EN 161
Seat size	<ul style="list-style-type: none">M2N : \varnothing 17mmM3N : \varnothing 23mm
Opening time (EN 161)	<ul style="list-style-type: none">M*N**F : < 0.5sM*N**S : < 10s
Closing time (EN 161)	<ul style="list-style-type: none">M*N**F : < 0.2sM*N**S : < 0.2s
Supply voltage	230Vac +10% -15%, 50/60Hz (other voltage on request)
Power consumption	34 VA, steady operation
IP rating	IP54 (with suitable connector) according to EN 60529
Electrical connections	DIN 43650 form A plug connector (not supplied)
Safety valves type of supply	Independant

Flow curves

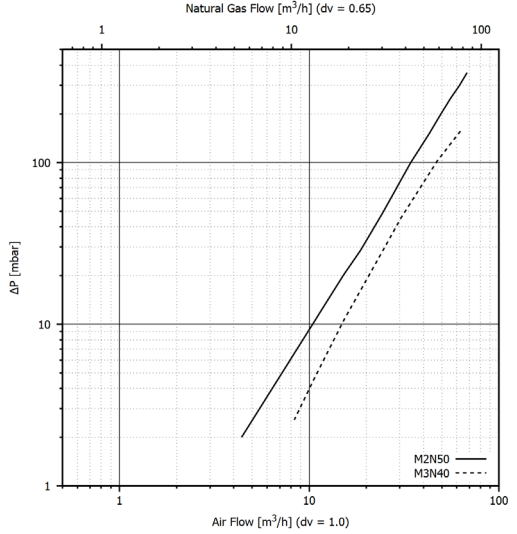

*P burner = 3 mbar
Flange = Rp3/4"*

*Maximum flow can be reduced
when other flanges are connected with.*

Operating principle

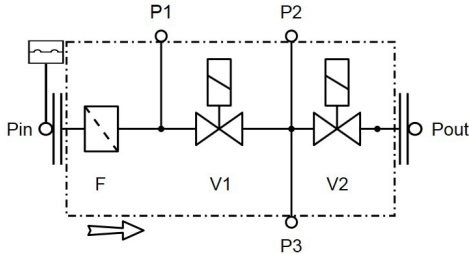

- P IN** : Inlet pressure
- P1** : Strainer pressure
- P2 / P3** : Intermediate pressure
- P OUT** : Outlet pressure
- F** : Strainer
- V1** : Safety shut-off valve 1
- V2** : Safety shut-off valve 2
- with flow limiter (for M*N**F)
- with hydraulic damper (for M*N**S)

Dimensional drawings

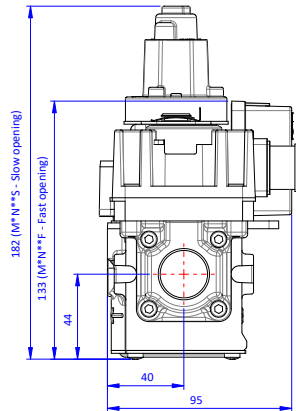
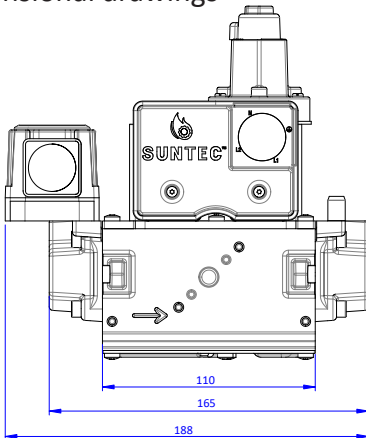

Working principle

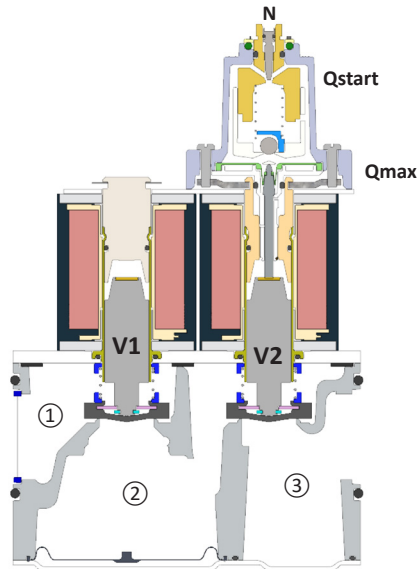

Safety valve

M*N combined gas valve comprises two automatic shut-off valves, electrically operated.

Each operator consists of a plunger connected to a rubber seal. A closing spring presses the seal against the seat, and thus ensures the tightness of the valve. At rest, both safety valves are closed; thus gas cannot flow beyond chamber ①.

When energized independently or simultaneously, the coils generate a magnetic field which moves up the plunger, and releases the gas flow from chamber ① to chamber ② for valve **V1** (from ② to ③ for **V2**).

A power-on indicator on the plastic cover lights up as valve **V1** is energized.

When de-energized, each safety valve closes within 0.2 second.

Flow adjustment

A setting screw, located on the valve **V2**, limits the opening stroke of plunger. It can be used to finely adjust the maximum gas flow.

Slow opening (M*N**S)

A hydraulic damper slows down the opening stroke of the safety valve **V2** and thus apply a progressive gas flow in the combustion chamber during the starting phase. The presence of a bypass allows to keep a fast opening of the safety valve **V2**, adjustable (**Qstart**) up to **80%** of the maximum flow.

Installation

Cautionary statements

Please read carefully these instructions before installing, commissioning or using the product ! Hazardous situation or damaging the product may result from their non-observance.

Herein specified ratings and product markings must be checked to ensure compatibility with the appliance.

The installation must only be carried out by a qualified technician.

A complete check of the installation must be carried out prior any start off.



Caution

- Turn off gas supply before installation.
- Disconnect power supply to the product before servicing to prevent any electrical shock and damage to the product
- The gas valve must be installed so that the gas flows in the same direction of the arrows. Reverse mounting may render valve inoperative.
- A complete check of the installation must be carried out prior any start off.

Mounting position

Any mounting position is allowed, as long as the safety valve axis do not point downwards as shown below.

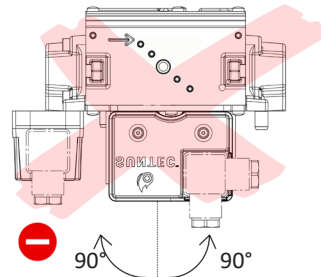
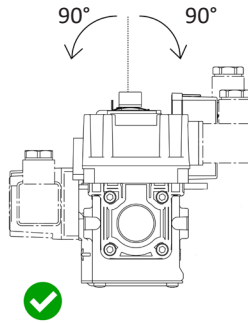
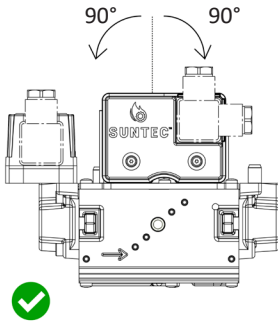

Gas connection

To prevent dirt from entering the gas valve during installation, inlet/outlet protective stickers should only be removed at the last moment.

- Apply thread sealant, sealing yarn or PTFE tape to the pipe threads. Type and amount should meet the vendor specifications.
- Screw the flanges onto the pipes.
- Check that the flanges are aligned and that spacing is sufficient to insert the valve between the flanges without damaging the O-ring seals.
- Remove inlet / outlet protective stickers and insert the 2 O-rings into their grooves. If necessary, small amount of grease can be used to hold them on.
- Fasten the valve to the flanges using the M5x20 screws supplied with the flanges. Make sure that the O-rings remain in place during this operation.
- Perform the electrical connection according to “Electrical connection” section page 6.

Leak proof test

Check for gas leaks of all pipe connections with a gas leak detection spray. To ensure an effective leak test of all connections, the gas valve must be energized (through the complete appliance) to raise pressure all over the valve.

In case of leak detection, gas supply must be shut off upstream and connection tightness redone.

Electrical connections



Caution

- All wiring must be executed in accordance with local codes and regulations.
- Lead wire should be selected to withstand maximum ambient and coil temperature.

Gas valve electrical connection must be done with DIN 43650 form A connector (not supplied).

Gas valve wiring is shown below. Please refer to the appliance manufacturer instructions for proper wiring:

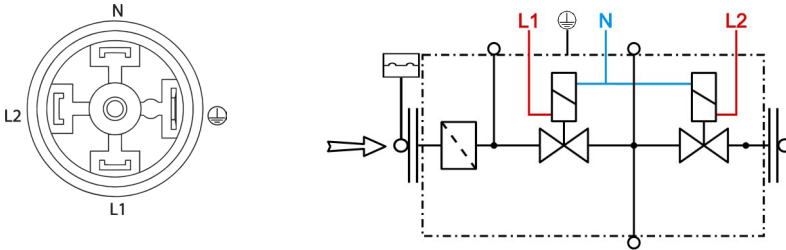

When the gas valve is powered, a green lamp lights up on the plastic cover. Please note that it is supplied in parallel of valve **V1**, therefore it will not light up when only valve **V2** is powered.

For pressure switch electrical connection, please refer to pressure switch instructions.

Gas valve adjustments

Flow adjustment (M*N**F - fast opening)

Flow can be adjusted by the screw located on the top of the safety valve **V2** with the help of a 3 mm hex key ①. Unscrew to increase the flow, screw gently to decrease.

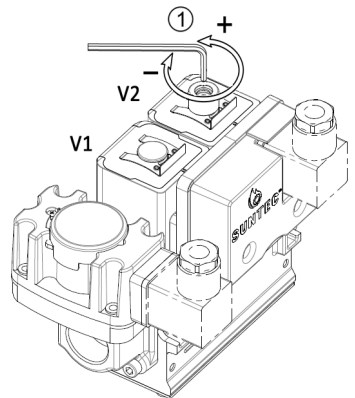

Caution

When fully screwed, the valve seal may be pressed against the seat. Do not apply **excessive torque** to avoid damaging the seal.

Flow adjustment (M*N**S - slow opening)

The main flow rate can be adjusted by unscrewing the two screws on the base of the hydraulic damper with a 3.5mm flat screwdriver.

Adjust the desired flow rate by rotating the body ②.

Tighten the two screws.

Tightening torque of the hydraulic damper: 0.4 N.m



For slow opening models, a minimum rest time of 25 seconds must be observed between 2 safety valve **V2** openings.

Fast stroke adjustment (M*N**S - slow opening)

To set the fast stroke remove the cap, reverse it upside down and use it as a tool to rotate the adjustment sleeve ③ between position **F** (fast to 80%) and **S** (slow opening for all stroke).

Refer to the position indicator on the top of the hydraulic damper.



Do not make any settings in the banned area (in grey on the diagram below).

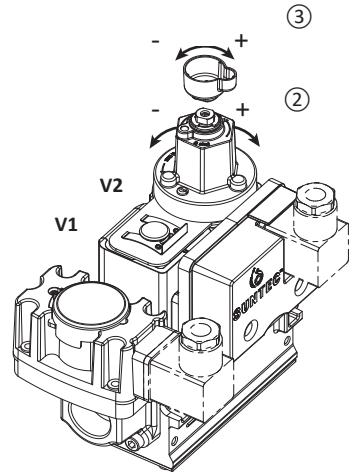
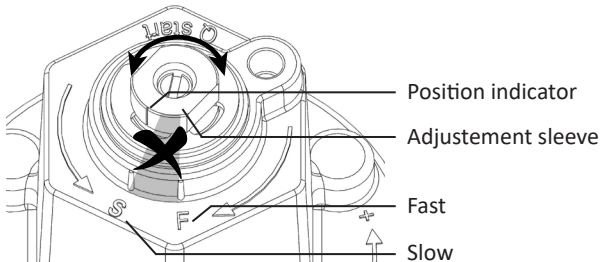

Opening time (M*N**S - slow opening)

The opening time is factory preset and does not need to be modified (sealing varnish on the needle screw).

With the factory setting, the opening time can be adjusted up to 10 seconds by adjusting the adjustment sleeve.

If necessary, contact SUNTEC for specific adjustment.



Pressure tap / pressure plugs identification

Default configuration for **M*N** gas valve consists of 1 pressure tap (**P OUT**), and 3 plugs (**P1**, **P2** and **P3**) as shown below.

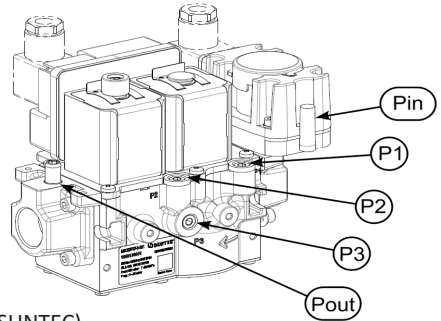
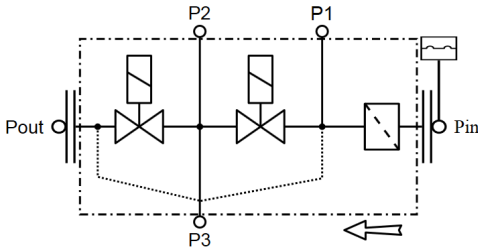

P3 pressure tap can be modified upon demand (consult SUNTEC).

Following pressure signal can be selected :

- Valve **V1** upstream pressure, after strainer,
- Pressure between Valve **V1** and Valve **V2**,
- Valve **V2** downstream pressure.



Caution

- To avoid any damage to the needle screw head, the use of an appropriate screwdriver is strongly recommended.
- To ensure the pressure tap tightness :
tightening torque must be 1 to 1.5 N.m for the needle screw of the pressure tap
tightening torque must be 3.5 N.m for the pressure tap.
- G1/8 Pressure taps can be removed using a 5 mm hex key.
- Perform a leak proof test after a modification.

Codification

	M2	N	5	0	F	0	7	-	2	-	XXXX
Gas valve size (Body / Seat)	_____	_____	_____	_____	_____	_____	_____	_____	_____	_____	_____
Pressure regulator type	_____	_____	_____	_____	_____	_____	_____	_____	_____	_____	_____
N = without pressure regulator											
Maximum inlet pressure / Valve class	_____	_____	_____	_____	_____	_____	_____	_____	_____	_____	_____
4 = 160 mbar - B + B (for M3 range)											
5 = 360 mbar - A + A (for M2 range)											
Regulator pressure range	_____	_____	_____	_____	_____	_____	_____	_____	_____	_____	_____
0 = No pressure regulator											
2nd safety valve opening	_____	_____	_____	_____	_____	_____	_____	_____	_____	_____	_____
F = Fast opening											
S = Slow opening											
Safety valves type of supply	_____	_____	_____	_____	_____	_____	_____	_____	_____	_____	_____
0 = Independent											
Coils voltage	_____	_____	_____	_____	_____	_____	_____	_____	_____	_____	_____
7 = 230V AC											
Revision	_____	_____	_____	_____	_____	_____	_____	_____	_____	_____	_____
Customization code	_____	_____	_____	_____	_____	_____	_____	_____	_____	_____	_____

Maintenance

Only the following items can be replaced during maintenance operation :

- Flange,
- Electronic block (This set is composed of 2 coils and an electronic board, do not disassemble),
- Pressure tap,
- Inlet strainer,
- O ring,
- Hydraulic damper (only for slow opening version M*N**S).

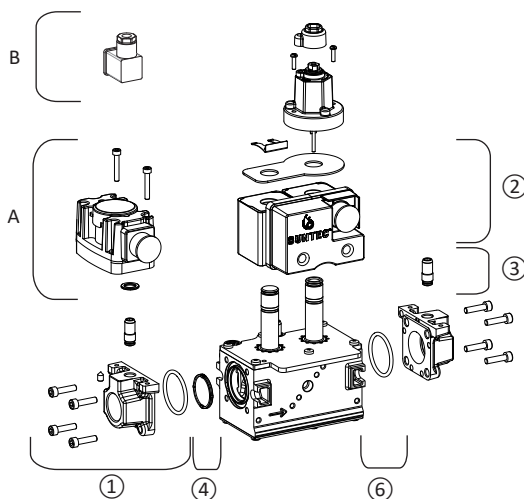

For any disassembly, refer to the instructions of the kits.



Caution

- The components listed must be SUNTEC parts.
- Any disassembly other than mentioned above is strictly forbidden.
- After replacing any of the above items and before operating the gas valve, check for gas leaks of all pipes connections with a leak detection.
- After any violent shock, such as an accidental dropping, the gas valve shall not be used anymore ; Internal and external tightness cannot be guaranteed.

Spare parts

Pos.	Part identification	Reference
①	Inlet/outlet Flange 3/4" with pressure tap	995001
①	Inlet/outlet Flange 1/2" with pressure tap	995002
②	Electronic block M*N/M*C	995003
③	Pressure tap	995004
④	Strainer	995005
⑤	O ring	995006
⑥	Hydraulic damper*	995007

*Only for slow opening version (M*N**S).

Accessories list

Pos.	Pressure switch	Range	Reference
A	DMG 010	2.0 - 10.0 mbar	8161002010
A	DMG 050	2.5 - 50.0 mbar	8161006050
A	DMG 150	5.0 - 150.0 mbar	8161004150
B	Electric plug	/	ENCO0_G

*SUNTEC provides another range of pressure switches adapted for direct threading on the pipelines (the F range).

ISO 9001 : 2015 Certification

AFAQ N° 1993/1573

Certificate of testing

We certify that all delivered products have been fully tested in accordance with SUNTEC INDUSTRIES France Quality Management System.



Declaration of Conformity

According to Regulation (EU) 2016/426.

Manufacturer's name: SUNTEC INDUSTRIES FRANCE
Manufacturer's address : 1 rue Lavoisier, CS 60102, F-21603 LONGVIC Cedex, France
Product description : Multifunctional gas control
Type : M2 and M3

SUNTEC INDUSTRIES FRANCE certifies that type M*N/M*C gas valves comply with the essential requirements of Regulation (EU) 2016/426 «Gas Appliances».

Certificate number : 1312CU6361

Type of products :

Model M2 :
M2C55S07-2, M2C52S07-2, M2N50S07-2,
M2C55F07-2, M2C52F07-2, M2N50F07-2
M2C55F07-1, M2C52F07-1, M2N50F07-1

Model M3 :
M3C45S07-2, M3C42S07-2, M3N40S07-2,
M3N40F07-2, M3C45F07-2, M3C42F07-2

The products are in compliance with the following directives, regulations and standards :

Regulation : **2016/426/EU** : Gas appliances

Directives : **2014/30/EU** : Electromagnetic Compatibility
2014/35/EU : Low voltage

Standards : **EN 13611** : Safety and control devices for burners
EN 161 : Automatic shut-off valves for gas appliances
EN 60730-1 : Automatic electrical controls
EN 126 : Multifunctional controls for gas burning appliances
EN 88-1 : Pressure regulators for inlet pressures up to 50 kPa

Notified body : Certigaz
Address : Immeuble Le Linéa, 1, rue du Général Leclerc, CS 60254, 92800 PUTEAUX CEDEX, FRANCE
Conformity process : Modul B+D

Longvic, october 7th 2021,
G. NOBLET
Q&E Manager

SUNTEC INDUSTRIES FRANCE
1, rue Lavoisier - CS 60102 - F-21603 LONGVIC Cedex
Tel. +33 (0) 3 80 70 60 70 - www.suntec.fr