

This is a general specification leaflet; for specific applications not covered herein, contact Suntec.

The SUNTEC ATUV oil pump is specially designed for the replacement market : the ATUV replaces the majority of two-stage pumps on the market of which most SUNTEC AT245, ATE245, models; it also can replace AT255, ATE255 models used with nozzles up to 5 GPH. It incorporates a blocking solenoid valve fitted with a built-in return valve ensuring an in-line cut-off function and a nozzle line pressure relief. It features two nozzle possible outlets.

COMPATIBILITY

- Domestic oil, HVO, B30 (biofuel blend with the addition of 30% FAME, as defined in DIN SPEC 51603-6), kerosene.
- Two firing rates
- Two-pipe system only (one pipe system not possible)

SPECIAL FEATURES

- Choice of nozzle outlet connection on either side (right or left).
- Nozzle line pressure relief device (for nozzles with build-in cut-off function).
- Performance and reliability of SUNTEC "AT2" pumps, also adapted to kerosene applications.

PUMP OPERATING PRINCIPLE

The gear set draws oil from the tank through the built-in filter and transfers it to the nozzle line via the cut-off solenoid valve. Pressure regulation is assured by two spool valves, one for each pressure mode. Switching between low and high pressure is assured by a "normally open" by-pass solenoid valve. When this solenoid is non-activated, a by-pass channel is open, allowing the normal functioning of the low pressure regulating valve which sets the nozzle pressure. When this solenoid is activated, the by-pass channel is closed, thus pressure will build up on both sides of the low pressure regulating valve eliminating its effect, and the high pressure regulating valve now determines the nozzle pressure.

Cut-off

The blocking solenoid valve of the nozzle line is of the "normally closed" type. This design ensures extremely fast response and the switching can be selected according to the burner operating sequence and is independent of motor speed. When this solenoid valve is non-activated, the valve is closed and all oil pressurized by the gear set passes through the regulators to suction line. As soon as this solenoid is activated, oil passes to the nozzle line at the pressure set by the pressure regulating valves.

Bleed

Bleeding in two pipe operation is automatic (it is assured by a bleed flat on the piston of the low pressure regulator). It may be accelerated by opening the pressure gauge port.

Caution: The non-used nozzle outlet must be loosened, thoroughly bled and re-tightened, to obtain a perfect cut-off function.

Nozzle line pressure relief

The nozzle line pressure relief function operates only when the installation is fitted with a nozzle incorporating a cut-off function which opens at 4 bars or above. Any subsequent expansion of the oil due to residual heat from the preheater or the boiler is discharged through the relief valve in the pump which opens at a lower pressure than the nozzle opening pressure.

Note : For a boosted pump, the overpressure applies to the safety shut-off device and the relief valve.

PUMP IDENTIFICATION

(2 models available)

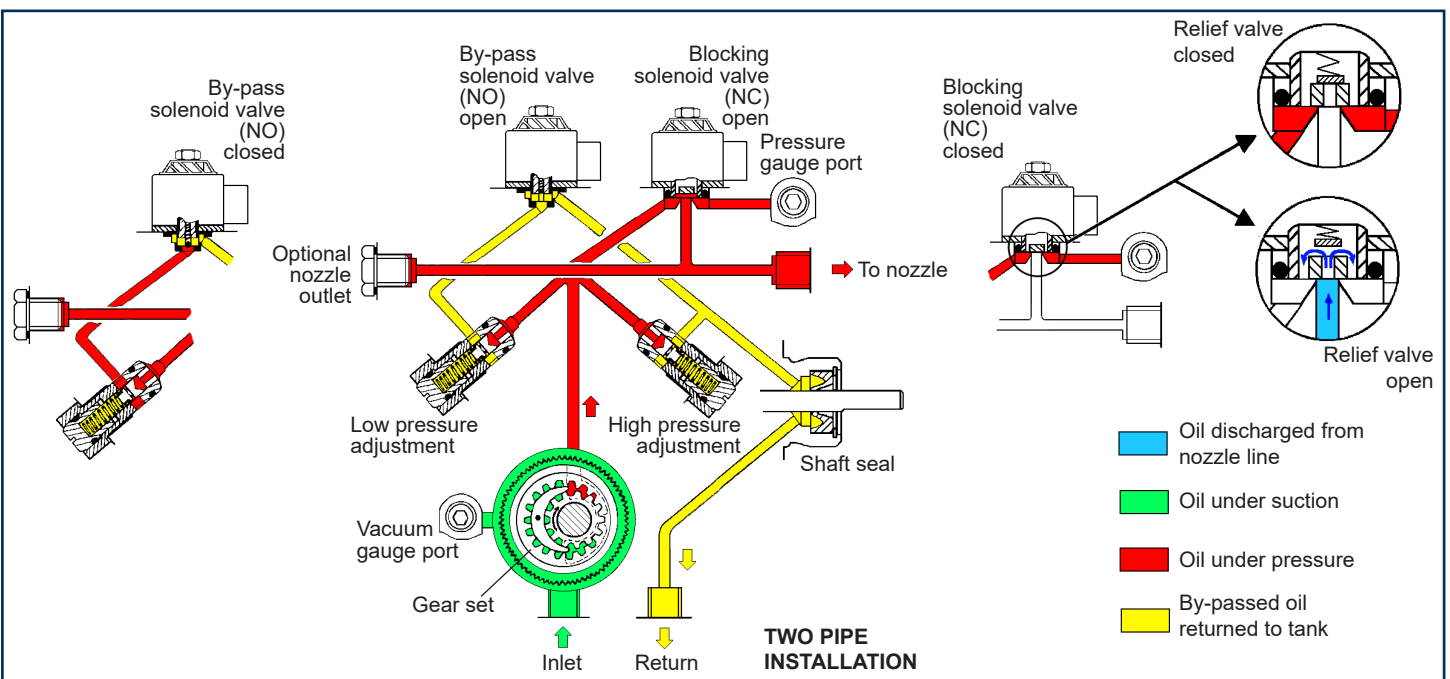
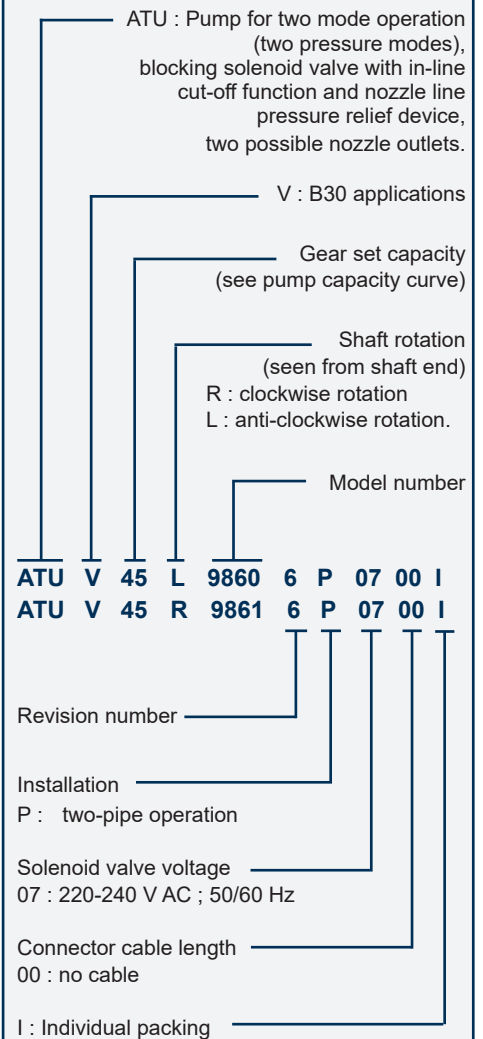

TECHNICAL DATA

General

Mounting	Hub mounting according to EN 225
Connection threads	cylindrical according to ISO 228/1
Inlet and return	G 1/4 (with facilities for conical sealing)
Nozzle outlets	G 1/8
Pressure gauge port	G 1/8
Vacuum gauge port	G 1/8
Valve function	Pressure regulation
Strainer	open area : 6 cm ² - opening size : 150 µm
Shaft	Ø 8 mm with 2 flats
Weight	1,3 kg

Hydraulic Data

Nozzle pressure ranges	Low mode	High mode
@ 1,8 cSt	2-12 bars	12 - 15 bars
@ 5 cSt	2-12 bars	12 - 25 bars
Delivery pressure settings	Low mode : 9 bars	High mode : 22 bars
Nozzle size applications	suitable for nozzles up to 3 GPH @1,8 cSt suitable for nozzles up to 5 GPH @ 5 cSt	
Viscosity range	1,25 - 12 mm ² /s (cSt)	
Oil temperature	0 - 60°C max. in the pump	
Inlet pressure	2 bars max.	
Return pressure	2 bars max.	
Suction height	0,45 bars max. vacuum to prevent air separation from oil	
Rated speed	3600 rpm max.	
Torque (@ 45 rpm)	0,10 N.m	

Solenoid valve characteristics

Voltage	220-240 V; 50/60 Hz
Consumption	9 W
Ambient temperature	0 - 80 °C
Maximum pressure	25 bars
Relief valve	3,5 bars max. (without booster)
opening pressure	
Certified	TÜV - Nr stamped on pump cover
Protection class	IP 54 according to EN 60529, when used with SUNTEC connector cable

Caution: When replacing an AT2 or ATE2 pump by an ATUV, take care of the inlet and return ports location and of the solenoid valves position. These ports and/or the solenoid valves may be inverted on the ATUV model with regard to the replaced model : refer to the arrows and the marking on the cover face of the pump, solenoid valve for switching low/high modes is identified with a label "2". ATUV models are only intended for two-pipe installations.

DIMENSIONS

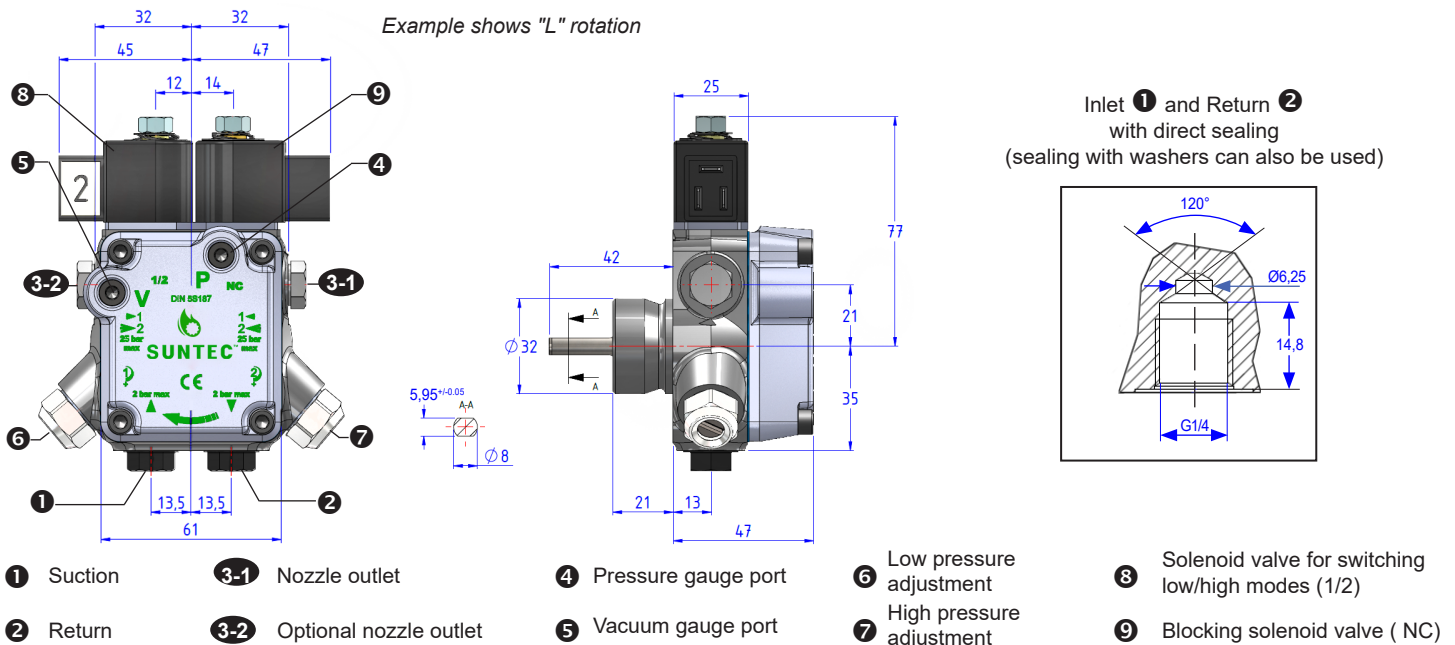

Pump capacity

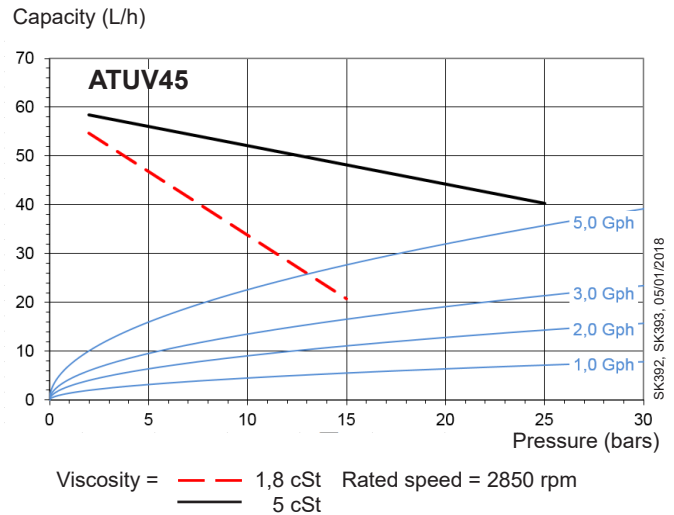

Data shown take into account a wear margin.
Do not oversize the pump when selecting the gear capacity.

Power consumption

